

REVISIONS			
REV.	DESCRIPTION	DATE	APPROVED

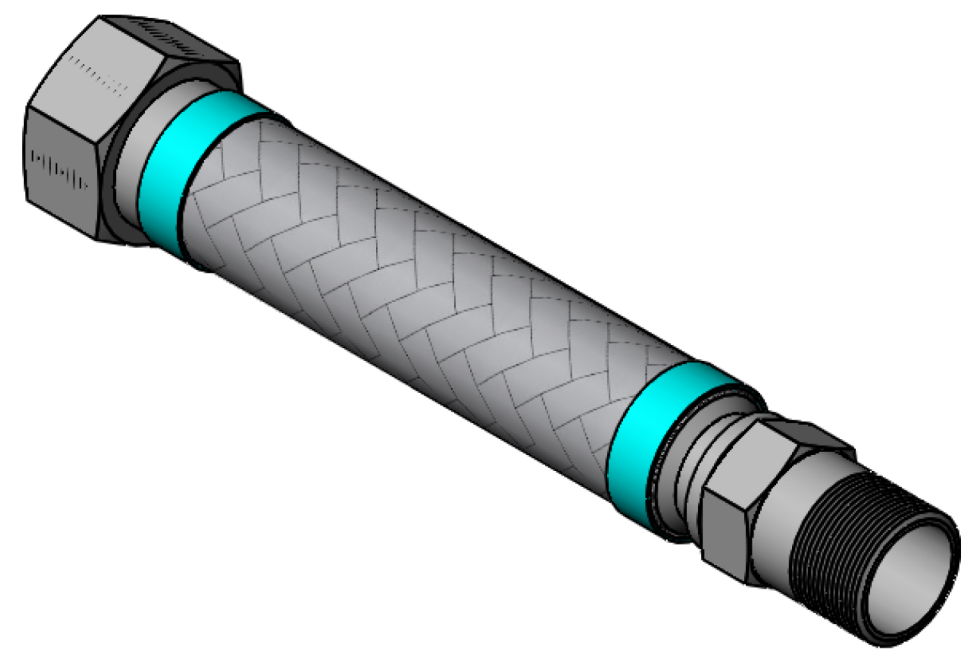

ITEM #	QTY.	PART NUMBER	DESCRIPTION	MATERIAL	WEIGHT
1	1	HOSE	300 Series Stainless HYDROFORMED Corrugated Hose	Stainless Steel	0.40
2	1	BRAID	300 Series Stainless Steel	Stainless Steel	0.04
3	2	BRAID COLLAR	0.05" Thick	Stainless Steel	0.07
4	1	2" FEMALE	2" Female, 2"x11-1/2" Thread, 2.38" Hex	Carbon Steel	0.76
5	1	1.5" MALE SWIVEL	1.5" Male Swivel, 1-1/2"x11-1/2" Thread, 1.94" Hex	Carbon Steel	1.40

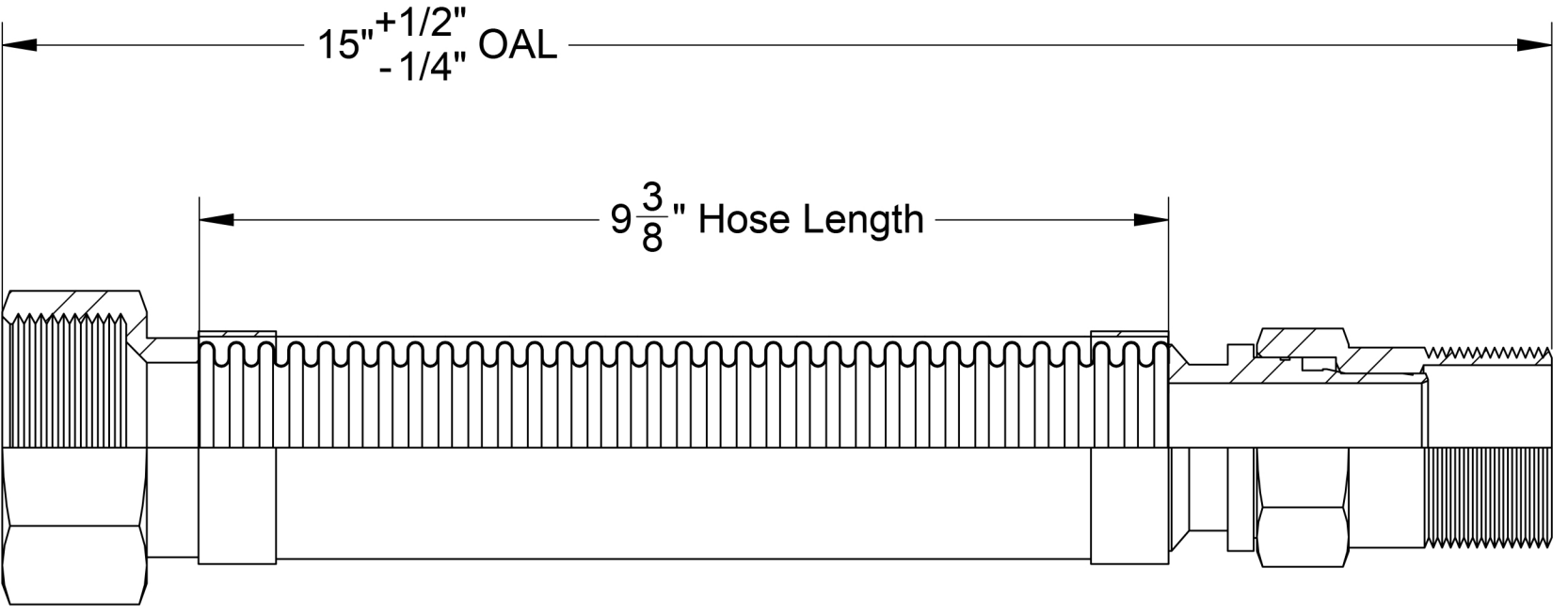

**HOSE MASTER Inc.**

1233 East 222nd Street • Cleveland, Ohio 44117  
 (800) 221-2319 • Fax: (216) 481-7557 • www.hosemaster.com  
 Locations: **Cleveland • Houston**

Registered to:  
ISO 9001 : 2000



Projection:	Customer: Hose Master Inc.	Prepared By: <b>kannk</b>
	Reference: Fire-Shield - 2" Female x 1.5" Male Swivel x 15" OAL	CALC. WEIGHT: <b>3 lbs.</b> Date: <b>9/24/2009</b>

Description: **1.5" ID x 15" OAL 300 Series Stainless HYDROFORMED Corrugated Hose covered by 300 Series Stainless Braid. UL Approved 2" Female Connector x 1.5" Male Swivel Connector**

Drawing #:	<b>FSFS0150x15</b>	Rev.:	-	SHEET 1 OF 1
------------	--------------------	-------	---	-----------------

